



Need customer support?

Call 855.454.3732

XMT-2500

AUTOMATIC SHUTTLE MAP/GAS
FLUSH HEAT SEAL MACHINE



The 2500 series Gas Flush sealers are our most versatile size packaging machines. Large enough to handle volume production in a factory setting, but small enough to be used in a one location operation, this mid-sized shuttle machine can be designed to seal most common containers and packaging in today's market. The larger machine size allows multiple containers to be sealed in one operation thus saving time, reducing film waste and maximizing inert gas consumption. Stock tooling is available in most common container shapes and sizes and customized tooling for your individual container application can be ordered with minimal lead times.



FAST

- Automatic feed and seal feature
- Display shows number of cycles sealed in shift
- 5 minute warm up time
- Simple pocket and die change over
- Seals up to 8 cycles per minute, depending on tray size and material



VERSATILE

- Interchangeable pockets and dies
- Custom pockets and dies available
- Choice of automatic or manual seal
- Optional date printer
- Adjustable heat settings & dwell time
- Registered print capability



SAFE

- Automatic Shut Off to Prevent Injury
- All moving mechanisms are guarded, closing off potential pinch points



QUALITY

- Die cuts around container for an attractive look
- Consistent, Leak-Proof Seals
- Film tensioner provides a wrinkle-free seal
- Low maintenance
- Heavy duty, stainless steel construction
- 12 month warranty on parts
- Digital controls with microcomputer program

 855.454.3732

 www.140packaging.com

 sales@140packaging.com



XMT-2500

AUTOMATIC SHUTTLE MAP/GAS
FLUSH HEAT SEAL MACHINE

Need customer support?

Call 855.454.3732



MACHINE DIMENSIONS

18.90" x 27.75" x 32.30"

MAX SIZE TRAY DIMENSIONS

12.60" x 9.85"

MAX WIDTH OF FILM

13.00"

MAX DIAMETER OF FILM ROLL

9.00"

MAX PACKAGING SPEED

1-up: 400 trays per hour

2-up: 800 trays per hour

4-up: 1,200 trays per hour

ELECTRICAL REQUIREMENTS

220 Volt, 1 Phase

POWER CONSUMPTION

10amps

NET WEIGHT

231 lbs

COMPRESSED AIR REQUIREMENTS

2HP Compressor

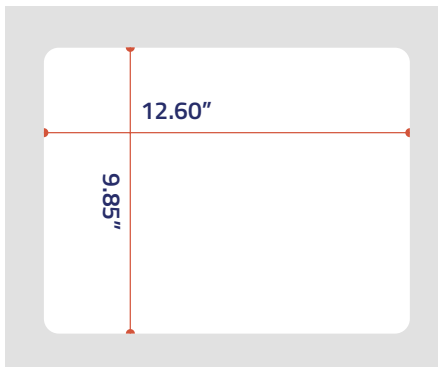

FOR ONE TRAY

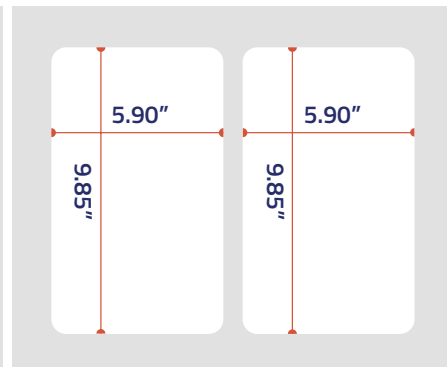

FOR TWO TRAYS

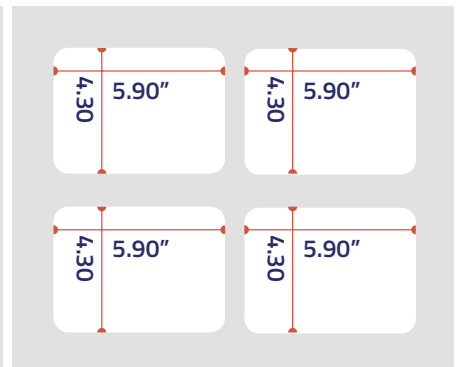

FOR FOUR TRAYS

855.454.3732

www.140packaging.com

sales@140packaging.com